

BT-3 160 (509816000)

GENERAL DATA

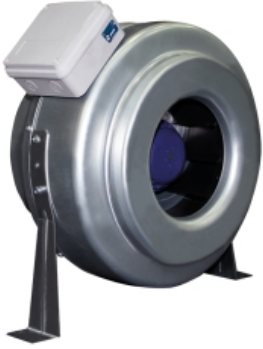

CENTRIFUGAL IN LINE WITH EXTERNAL ROTOR MOTOR

MANUFACTURING FEATURES:

- Housing in galvanized sheet.
- Backward impeller dynamically balanced.
- External connection box.
- Single-phase asynchronous motor with external rotor, including thermal protector for automatic resetting and long-life permanent lubrication ball bearings (40,000 hours). Protection IP-44. Standard voltage 230V 50/60Hz (except 315 size which has different motor at 50Hz than 60Hz)
- Supplied with support feet (optional mounting)

APPLICATIONS:

Designed for duct installation, suitable for false ceiling, are indicated for:

- Renovation of air in bathrooms and small rooms.
- Maximum continuous working temperature: 50°C.
- Fan not suitable for transporting explosive gases.

PERFORMANCE CURVE

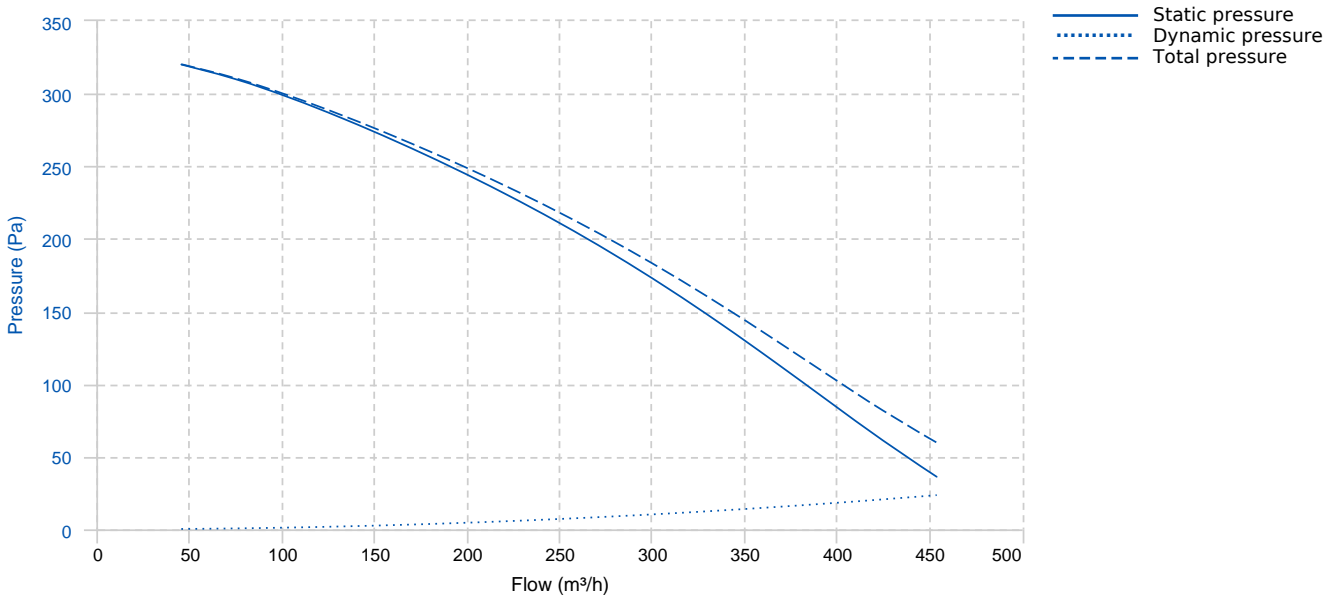

TECHNICAL DATA

Fan

RPM	2760	Approx. weight	3.5 kg	Max. Flow	460 m³/h
-----	------	----------------	--------	-----------	----------

Motor

Power	0,075 kW	RPM	2760	I max. (230V)	0,34 A
-------	----------	-----	------	---------------	--------

DIMENSIONS

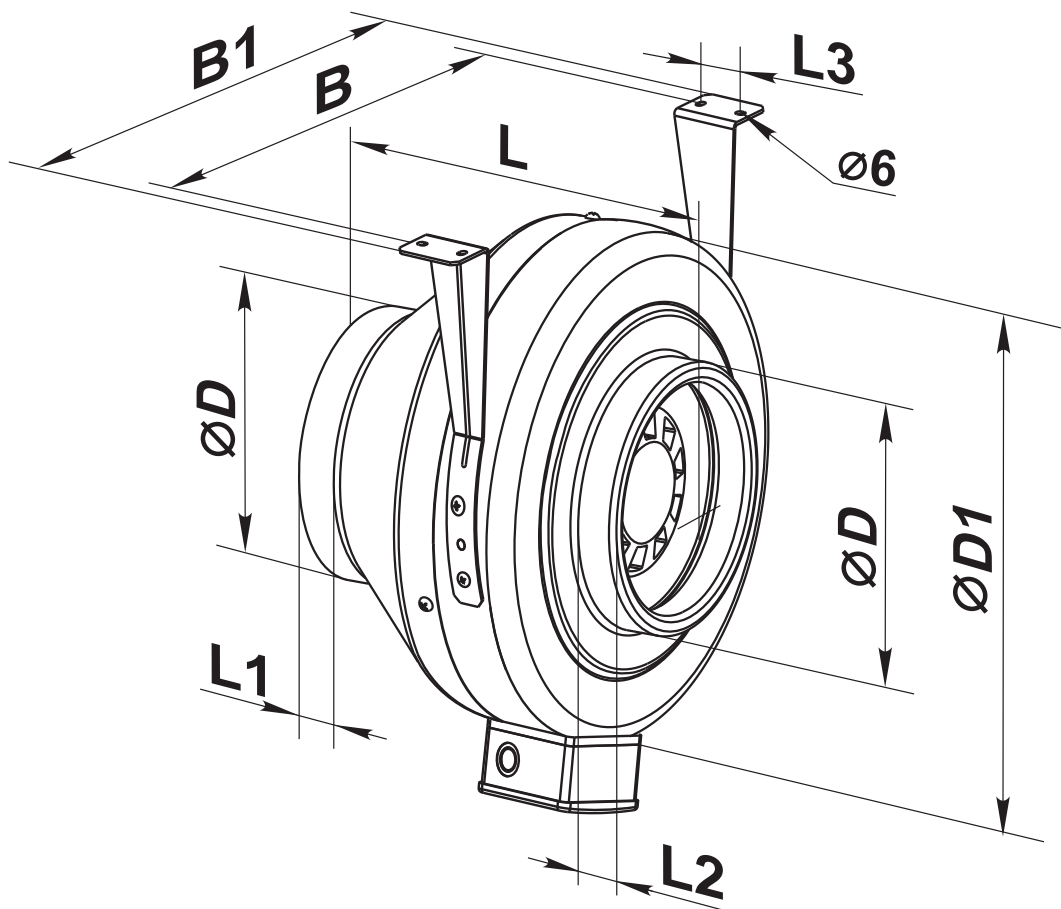

Dimensions (mm)

B	294	B1	334	L	200	L1	25	L2	23
L3	30	ØD	158	ØD1	278				

WIRING DIAGRAM

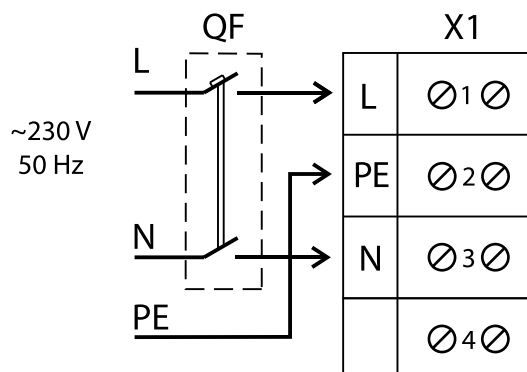

ACCESSORIES



**MANUAL SINGLE PHASE SPEED CONTROLLER
REG 1,5A
REF: 960710015**



**SAFETY SWITCH
INT 25 3P A
REF: INT253PA**



**ANTI-VIBRATION JOINT
JE 45
REF: 300719201**



**MANUAL SINGLE PHASE SPEED CONTROLLER
REGD-1
REF: 300782600**



**CIRCULAR SOUND ATTENUATOR IN GALVANISED
STEEL
SILC-MINI 160
REF: SILCM160**