

# HJBM 45 0,75kW EEC (1420rpm) (268451103V2)

## GENERAL DATA



WALL MOUNTED FAN WITH SQUARE FRAME, VARIABLE PITCH BLADES AND ELECTRONIC MOTOR

### MANUFACTURING FEATURES

- Square plate made of galvanized steel sheet.
- Variable pitch angle polyamide impeller reinforced with fibreglass.
- Supplied with motor support and protection guard according to the ROHS 2002/95/EC Directive (Restriction of the Use of Certain Hazardous Substances in Electrical and Electronic Equipments).
- PM brushless motor (permanent magnets), synchronous, electronically commutated, high efficiency and low sound level. Specially designed for fans with electronic operation and control in deported box IP65.

Working range: from 400 to 1200-2000rpm (depending on the models)

Motor with IP54 protection and class F insulation. IP 65 drive case

Power: 220V  $\pm$  10% single phase

Power frequency: 50 / 60Hz

Operating temperature range: -20°C to 50°C

Speed control through signal 0-10V or PWM

### APPLICATIONS

Designed for wall assembly, they are suitable for:

- Air renewal for all kind of buildings and industries.

### UNDER REQUEST

- B form impeller (air flow from impeller to motor).
- Aluminium impeller.

## PERFORMANCE CURVE

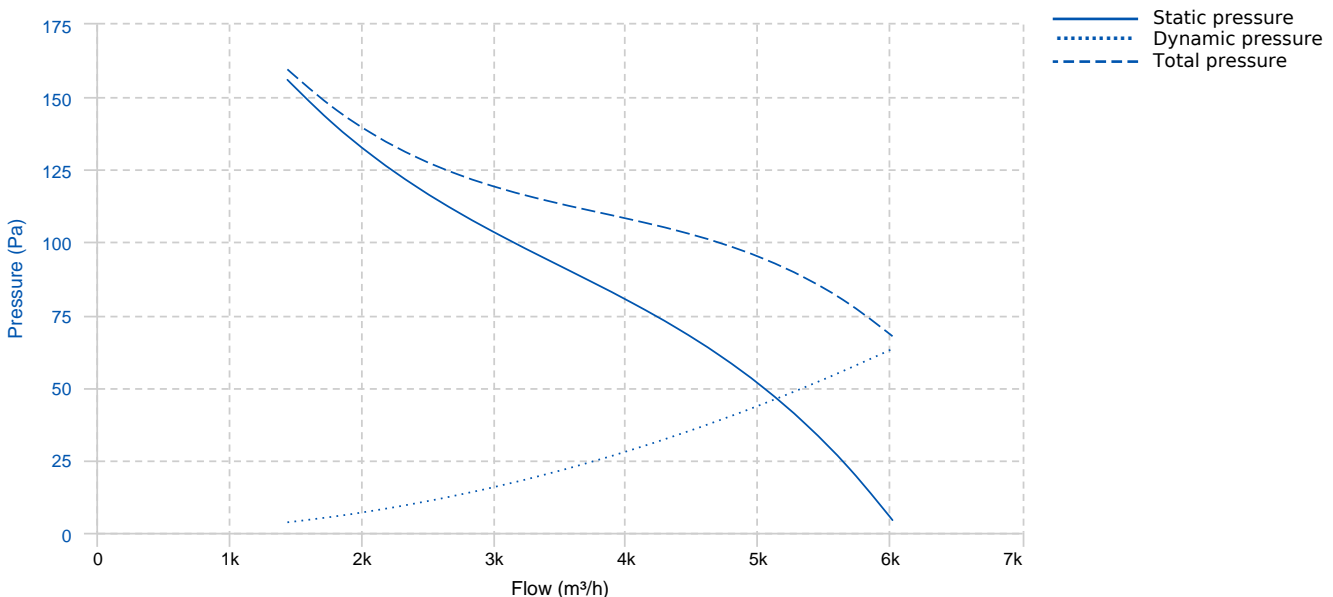

## TECHNICAL DATA

Fan							
RPM	1420	Approx. weight	12.5 kg	Max. Flow	6020 m <sup>3</sup> /h		
Motor							
Power	0,75 kW	RPM	1420	I max. (230V)	5,8 A	Size	80
Approx. weight	0 kg						

## ERP DATA

Fan data sheet		
Fan type	Axial fan	
Installation category	A: Outlet and Inlet free discharge	
Efficiency category	Static	
The fan has to be installed with VF	No	
Motor power (kW)	0.75	
	Fan values	ERP Requirements 2015
Max. efficiency (%)	41.55	29.6
Efficiency grade (N)	51.95	40
Pabs (kW)	0.226	
Flow (m <sup>3</sup> /h)	3648.48	
Static pressure (Pa)	88.46	
Speed (m/s)	1420	
Specific ratio	1.00	

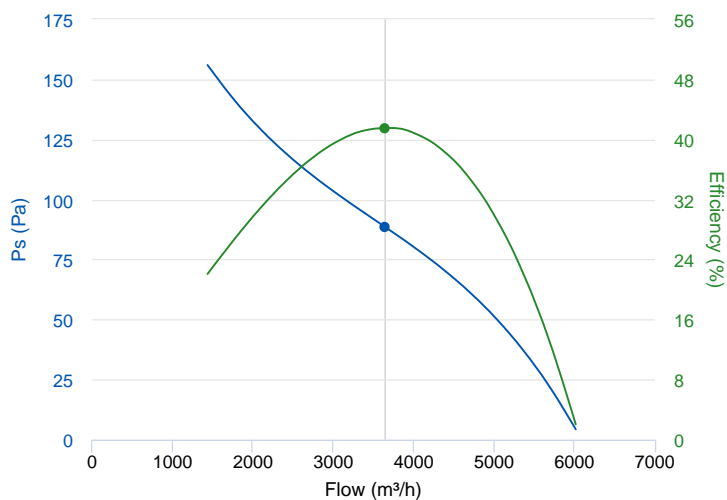

## DIMENSIONS

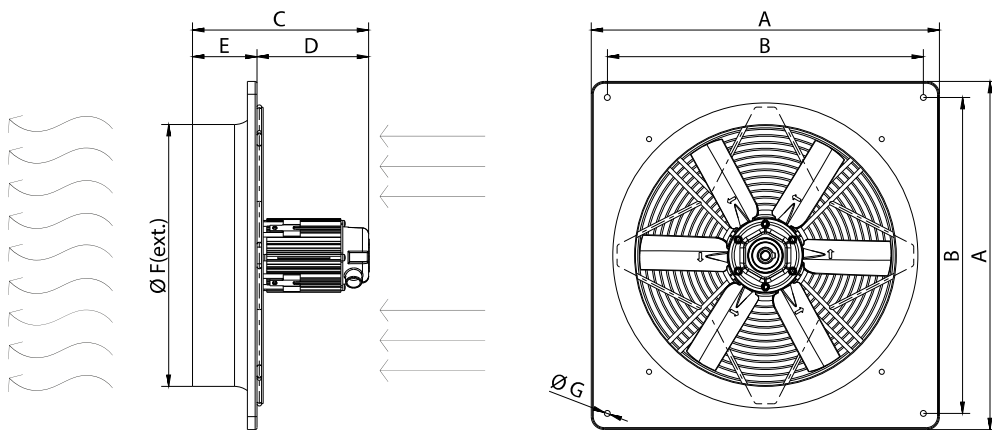

### Dimensions (mm)

A	576	B	521.5	C	285.4	D	186.9	E	98.5
F	455	G	11						

## WIRING DIAGRAM

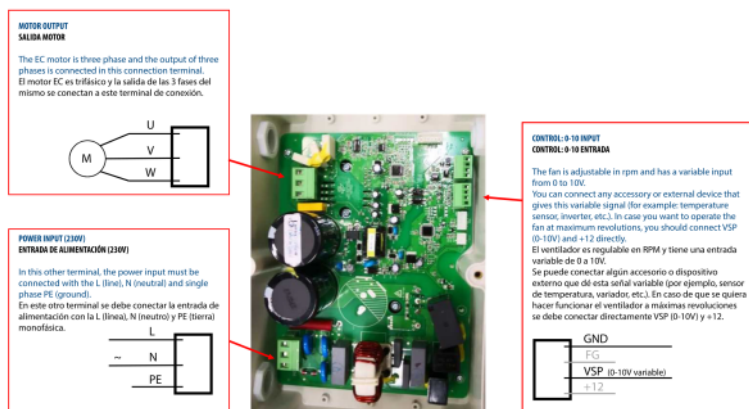

## ACCESSORIES



**SAFETY SWITCH**  
**INT 25 3P A**  
**REF: INT253PA**



**Outlet protection guard for axial fans**  
**RPO 45**  
**REF: 980000045**



**PLASTIC GRAVITY SHUTTER**  
**PCP 45**  
**REF: 963240105**



**SPEED CONTROLLER FOR EEC MOTOR**  
**REGC**  
**REF: FX263300**



**ALUMINIUM GRAVITY SHUTTER**  
**PC2 50**  
**REF: PC25050**

## SPARE PARTS

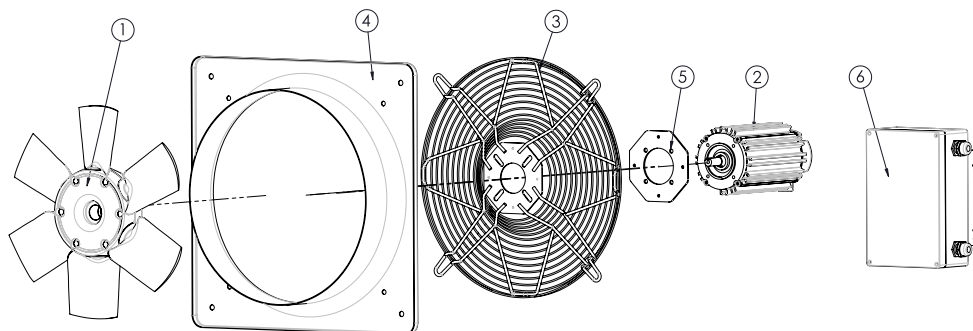

	Code	Model	Qty
1	R-H45006240PSTD	IMPELLER 450:AP0:6 G40 D14	x1
2	720331075IEC4V2	MOTOR EEC 750W (T,80)	x1
3	R-268451902	PROTECTION GRID HJBM45	x1
4	R-268451779A001	FRAME HJBM-HJBM EEC45	x1
5	R-266401909	SUPPORT MOTOR DISC HJBM30-35-45 T.80	x1
6	301002104R142	ELECTRONICAL DEVICE EEC750 1420RPM	x1