

# HJBM PLUS 25 M2 0,18kW (268253103)

## GENERAL DATA



SQUARE WALL PLATE FAN, VARIABLE PITCH BLADES AND HIGH EFFICIENCY MOTOR

### MANUFACTURING FEATURES

- Square plate made of galvanized steel sheet with polyester painting.
- Variable pitch angle polyamide impeller reinforced with fibreglass.
- Supplied with motor support and protection guard according to the UNE-EN 20-359-74 norm and the ROHS 2002/95/EC Directive (Restriction of the Use of Certain Hazardous Substances in Electrical and Electronic Equipments).
- High efficiency standard asynchronous squirrel-cage motor with IP-55 or IP-54 protection (wiring box IP-65) and Class F insulation. Manufactured with standard voltages: 230V 50Hz for the single phase motors and 230/400V 50Hz for the three phase motors.

### APPLICATIONS

Designed for wall assembly, they are suitable for:

- Air renewal in buildings and industries.
- Maximum working temperature: single phase 50°C, three phase 60°C.

### UNDER REQUEST

- Aluminium impeller.
- 60Hz fans.

## PERFORMANCE CURVE

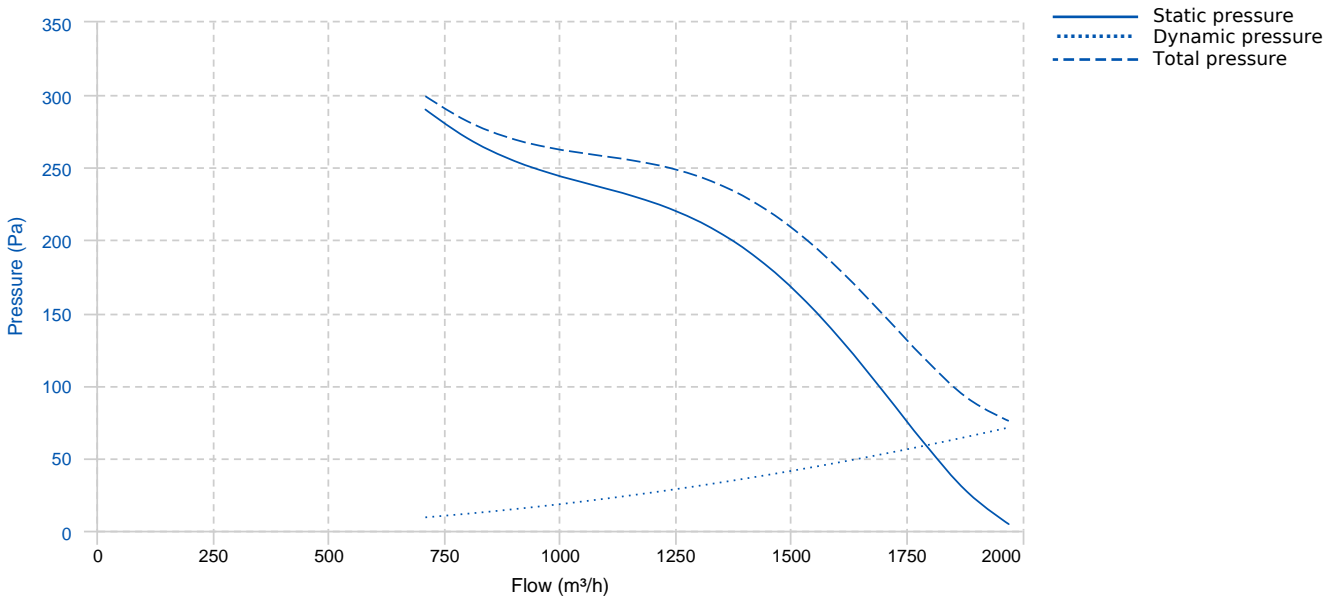

## TECHNICAL DATA

Fan							
RPM	2790	Approx. weight	4.5 kg	Max. Flow	1980 m³/h		
Motor							
Power	0,18 kW	RPM	2790	Capacitor	8µF 450V	I max. (230V)	1,36 A
Size	63	Approx. weight	4.2 kg	Efficiency (%)	60,4 %	FP	0,95

## ERP DATA

Fan data sheet		
Fan type	Axial fan	
Installation category	A: Outlet and Inlet free discharge	
Efficiency category	Static	
The fan has to be installed with VF	No	
Motor power (kW)	0.18	
	Fan values	ERP Requirements 2015
Max. efficiency (%)	30.15	29.92
Efficiency grade (N)	40.23	40
Pabs (kW)	0.255	
Flow (m³/h)	1313.62	
Static pressure (Pa)	210.73	
Speed (m/s)	2790	
Specific ratio	1.00	

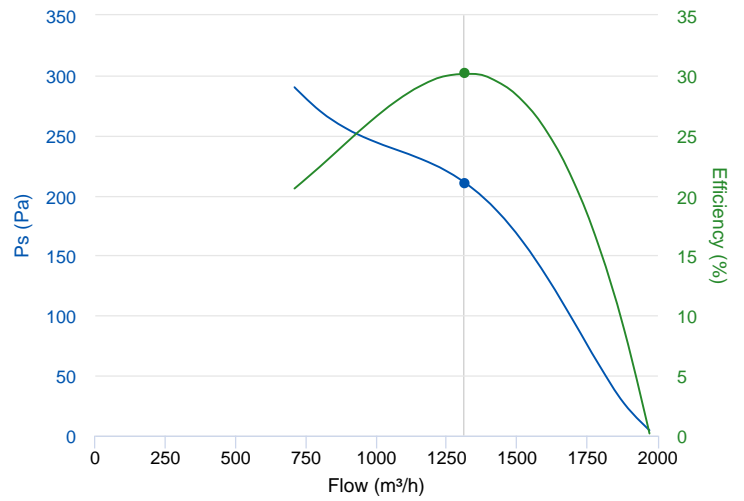

## DIMENSIONS

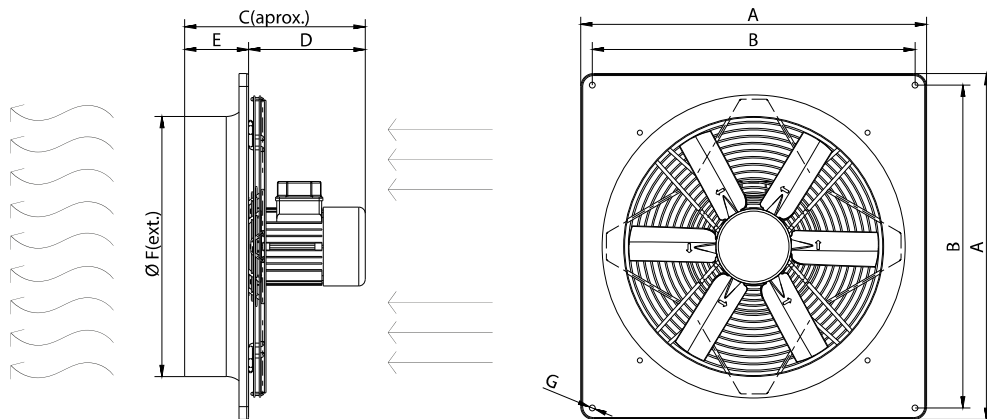

## Dimensions (mm)

A	370	B	320	C	270,8	D	192,8	E	78
ØF	253	ØG	7						

## WIRING DIAGRAM

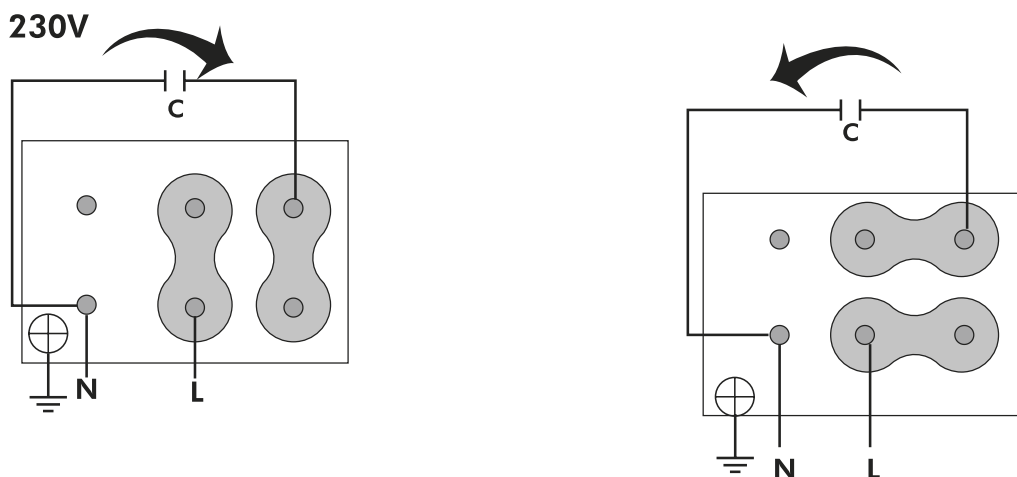

## ACCESSORIES



**SAFETY SWITCH**  
**INT 25 3P A**  
**REF: INT253PA**



**Outlet protection guard for axial fans**  
**RPO 25**  
**REF: 980000025**



**PLASTIC GRAVITY SHUTTER**  
**PCP 25**  
**REF: 963200105G**

## SPARE PARTS

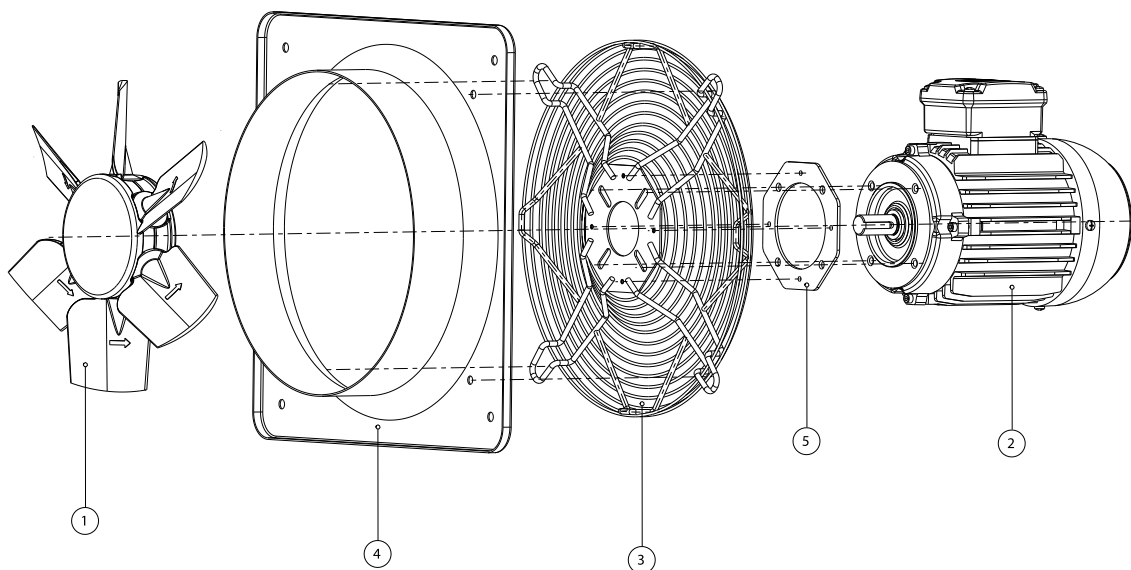

	Code	Model	Qty
1	R-H25006130PSTD	IMPELLER 250:AP0:6 G30:D11	x1
2	720301024	MOTOR 0,18kW M2 B14 230V	x1
3	R-268251902	PROTECTION GRID HJBM25	x1
4	R-268251778A001	FRAME HJBM25	x1
5	R-268401909	SUPPORT MOTOR DISC HJBM25-30-35-40 T.63	x1